



Micro Commercial Components

Micro Commercial Components  
20736 Marilla Street Chatsworth  
CA 91311  
Phone: (818) 701-4933  
Fax: (818) 701-4939

# DTC114TCA

## Features

- Case Material: Molded Plastic. UL Flammability Classification Rating 94V-0 and MSL Rating 1
- Built-in bias resistors enable the configuration of an inverter circuit without connecting external input resistors (see equivalent circuit)
- The bias resistors consist of thin-film resistors with complete isolation to allow negative biasing of the input. They also have the advantage of almost completely eliminating parasitic effects
- Only the on/off conditions need to be set for operation, making device design easy

## Absolute Maximum Ratings

Parameter	Symbol	Value	Unit
Collector-Base Voltage	$V_{CBO}$	50	V
Collector-Emitter Voltage	$V_{CEO}$	50	V
Emitter-Base voltage	$V_{EBO}$	5	V
Collector Current-Continuous	$I_C$	100	mA
Collector Dissipation	$P_C$	200	mW
Junction Temperature	$T_J$	150	$^{\circ}C$
Storage Temperature Range	$T_{STG}$	-55~150	$^{\circ}C$

## Electrical Characteristics

Sym	Parameter	Min	Typ	Max	Unit
$V_{(BR)CBO}$	Collector-Base Breakdown Voltage ( $I_C=50\mu A, I_E=0$ )	50	---	---	V
$V_{(BR)CEO}$	Collector-Emitter Breakdown Voltage ( $I_C=1mA, I_B=0$ )	50	---	---	V
$V_{(BR)EBO}$	Emitter-Base Breakdown Voltage ( $I_E=50\mu A, I_C=0$ )	5	---	---	V
$I_{CBO}$	Collector Cut-off Current ( $V_{CB}=50V, I_E=0$ )	---	---	0.5	$\mu A$
$I_{EBO}$	Emitter Cut-off Current ( $V_{EB}=4V, I_C=0$ )	---	---	0.5	$\mu A$
$h_{FE}$	DC Current Gain ( $V_{CE}=5V, I_C=1mA$ )	100	300	600	---
$V_{CE(sat)}$	Collector-Emitter Saturation Voltage ( $I_C=10mA, I_B=1mA$ )	---	---	0.3	V
$R_1$	Input Resistor	7	10	13	$K\Omega$
$f_T$	Transition Frequency ( $V_{CE}=10V, I_C=-5mA, f=100MHz$ )	---	250	---	MHz

## NPN Digital Transistor

### SOT-23

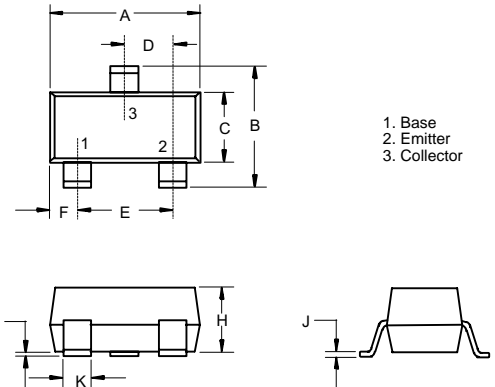

#### DIMENSIONS

DIM	INCHES		MM		NOTE
	MIN	MAX	MIN	MAX	
A	.110	.120	2.80	3.04	
B	.083	.098	2.10	2.64	
C	.047	.055	1.20	1.40	
D	.035	.041	.89	1.03	
E	.070	.081	1.78	2.05	
F	.018	.024	.45	.60	
G	.0005	.0039	.013	.100	
H	.035	.044	.89	1.12	
J	.003	.007	.085	.180	
K	.015	.020	.37	.51	

### Suggested Solder Pad Layout

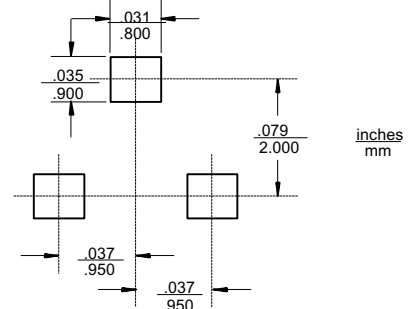

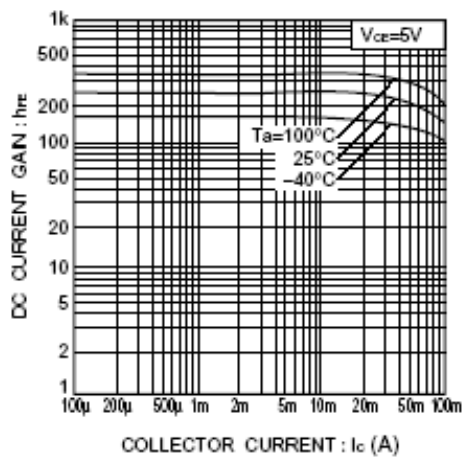

Fig.1 DC current gain vs. collector current

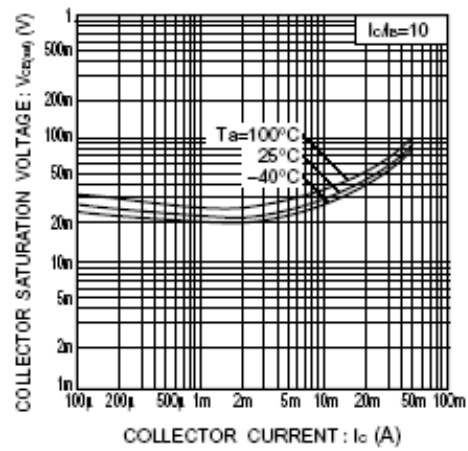
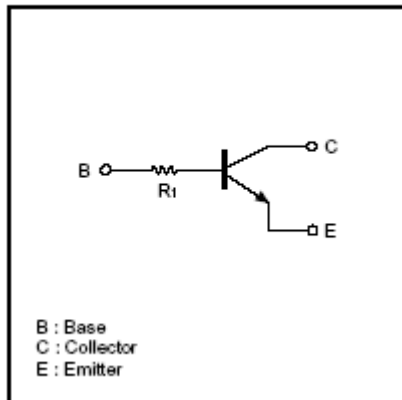

Fig.2 Collector-emitter saturation voltage vs. collector current

●Equivalent circuit





Micro Commercial Components

## Ordering Information

Device	Packing
(Part Number)-TP	Tape&Reel;3Kpcs/Reel

**\*\*\*IMPORTANT NOTICE\*\*\***

*Micro Commercial Components Corp.* reserves the right to make changes without further notice to any product herein to make corrections, modifications, enhancements, improvements, or other changes. *Micro Commercial Components Corp.* does not assume any liability arising out of the application or use of any product described herein; neither does it convey any license under its patent rights, nor the rights of others. The user of products in such applications shall assume all risks of such use and will agree to hold *Micro Commercial Components Corp.* and all the companies whose products are represented on our website, harmless against all damages.

**\*\*\*APPLICATIONS DISCLAIMER\*\*\***

Products offer by *Micro Commercial Components Corp.* are not intended for use in Medical, Aerospace or Military Applications.